

# TAP650 Series

High-power, low profile design



## FEATURES

- For variable speed drives, power supplies, control devices, robotics, motor control and other power designs.
- High-purity ceramic metalized with film on bottom for better heat transfer and optimum discharge.
- Encapsulation: Special resin-filled epoxy casing. High insulation resistance (CTI 600), high dielectric strength and partial discharge capability.
- Resistance Element: Special design for low inductance and capacitance values. The element demonstrates stability while covering high wattage and pulse load-ing.



## CHARACTERISTICS

**Power rating** 650W at 85°C bottom case temp. (Please ask for detailed mounting procedure! This value is only applicable if using thermal conduction to the heat sink  $R_{th-cs} < 0.117^\circ\text{K/W}$ . This value can be obtained by using a thermal transfer compound with a heat conductivity of 8.55 W/mK. The flatness of the cooling plate must be better than 0.05mm overall. Surface roughness should not exceed 6.4µm.

### Derating

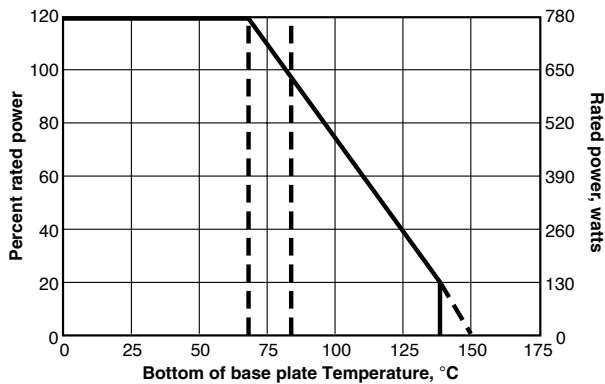

Test	Method	Typical results
Short time overload	1,000W/10sec	0.4%
Humidity steady state	56 days/40°C/95%	0.25%
Temp. cycling	-55°/+125°/5 cycles	0.20%
Shock	40g/4,000 times	0.25%
Vibrations	2-500Hz/10g	0.25%
Load life	3,000cyl; Pn 30 min. on / 30 min off	0.40%

<b>Resistance values</b>	0.25Ω to 1MΩ (others upon request). Values below 1 ohm are measured at max lead length.
<b>Resistance tolerance</b>	±5% to ±10%
<b>Temperature coefficient</b>	±150 ppm/°C (others upon request)
<b>Maximum working voltage</b>	5,000VDC, higher voltage upon request, not exceeding max. power
<b>Short time overload</b>	1,000 W at 70°C for 10sec., delta-R = 0.4% max.
<b>Power rating</b>	650W at 85°C bottom case temperature (others upon request)
<b>Peak current</b>	up to 1,500A depending on pulse length and frequency. Please ask for details!
<b>Electric strength voltage</b>	6kVrms, 50 Hz, up to 12 kVrms upon special request.
<b>Single shot voltage</b>	up to 12kV norm wave (1.5/50 µsec)
<b>Partial discharge</b>	4kVrms, <10 pC, up to 7kV upon special request
<b>Insulation resistance</b>	10 GΩ min. at 500V
<b>Inductance</b>	80nH (typical)
<b>Capacity/mass</b>	110 pF
<b>Capacity/parallel</b>	40 pF
<b>Operating temperature</b>	res. body: -55°C to +150°C; std. cables: -40°C to +120°C (other cables upon request)
<b>Mounting max. torque</b>	1.8 Nm, M4 screws
<b>Housing material</b>	According to UL94-V0
<b>Standard storage conditions</b>	0° to 85°C at 80% RH max. for min. 12 months. For different conditions please contact factory
<b>Derating (thermal resist.)</b>	8.55W/°K (0.117°K/W)

(continued)

# TAP650 Series

High-power, low profile design

## DIMENSIONS

(in./mm)

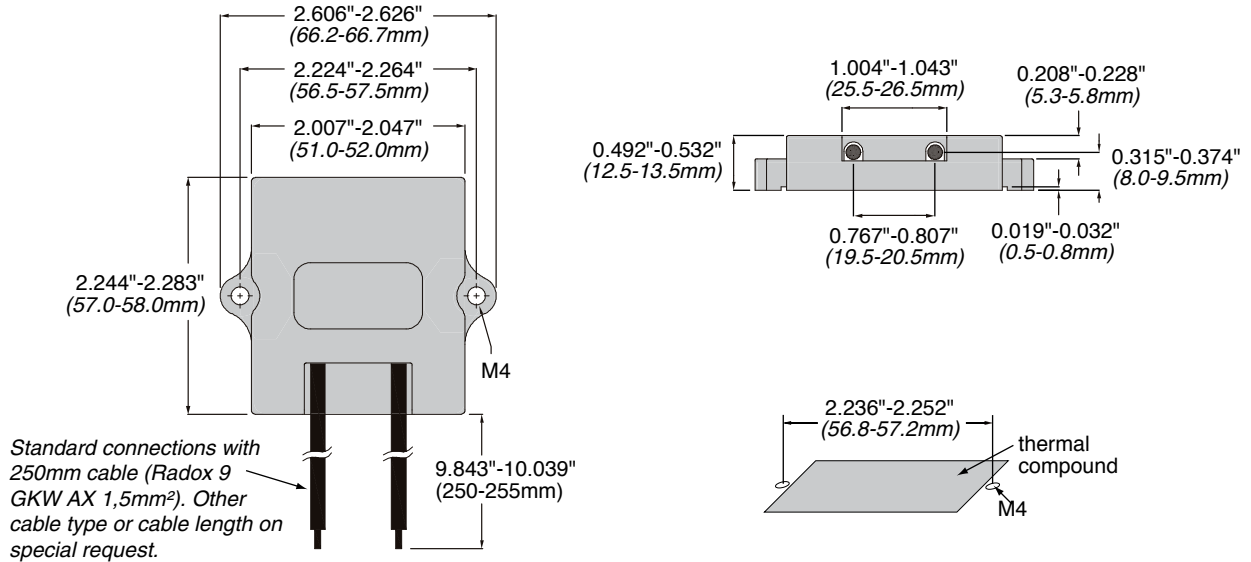

## ORDERING INFORMATION

RoHS compliant  
Non-compliant version  
unavailable

**TAP650J5R0E**

Style      Tolerance      Resistance

J = 5%, std.      1 Ohm = 1R0

K = 10%      10 Ohm = 10R

L = 20%      1000 Ohm = 1K0

### Standard part numbers

TAP650JR25E	TAP650J100E
TAP650JR50E	TAP650J270E
TAP650J1R0E	TAP650J500E
TAP650J4R7E	TAP650J1K0E
TAP650J10RE	TAP650J2K5E
TAP650J27RE	TAP650J5K0E
TAP650J36RE	TAP650J7K5E
TAP650J50RE	TAP650J10KE
TAP650J75RE	

### THIS PRODUCT IS DESIGNED FOR USE WITH PROPER HEATSINKING.

Maximum base plate temperature of the resistor must be monitored and kept within specified limits to establish the power rating. Best technique is to attach a thermocouple to the side of the base plate of the resistor. Temperature of plastic housing or heat sink cannot be used to establish rating of the resistor. The Ohmite CP4 (<https://www.ohmite.com/cp4-series-chillplate/>) is an example of properly designed heat sink.